



**NATURAL SCIENCES
ADMISSIONS ASSESSMENT**

D568/12

Wednesday 31 October 2018

40 minutes

SECTION 2

* 4 1 0 3 3 3 1 1 9 0 *

Candidate number	N						Centre number						
------------------	---	--	--	--	--	--	---------------	--	--	--	--	--	--

	d	d			m	m			y	y	y	y
Date of birth			-			-						

First name(s)	
---------------	--

Surname / Family name	
-----------------------	--

INSTRUCTIONS TO CANDIDATES

Please read these instructions carefully, but do not open the question paper until you are told that you may do so. This paper is Section 2 of 2.

There are six questions in this paper, of which you should answer any **two**.

There are 20 marks for each question. In total 40 marks are available.

You should write your answers in the spaces provided in this question paper. Please complete this section in **black pen**. Pencil may be used for graphs and diagrams only.

You can use the blank pages inside this booklet for rough working or notes, but **no extra paper** is allowed. Only answers in the spaces indicated in the paper will be marked.

Calculators may be used in this section. Please record your calculator model in the box below:

Calculator model	
------------------	--

Write the numbers of the questions you answer in the order attempted in the boxes below:

Question number

Please wait to be told you may begin before turning this page.

This question paper consists of 28 printed pages and 4 blank pages.

PV5

This page is intentionally left blank for your rough working or notes.

Physics

Question P1

A ball of mass m is dropped and falls vertically from a high window. The graph illustrates the height of the ball above the ground, h , as a function of time t since the ball was dropped.

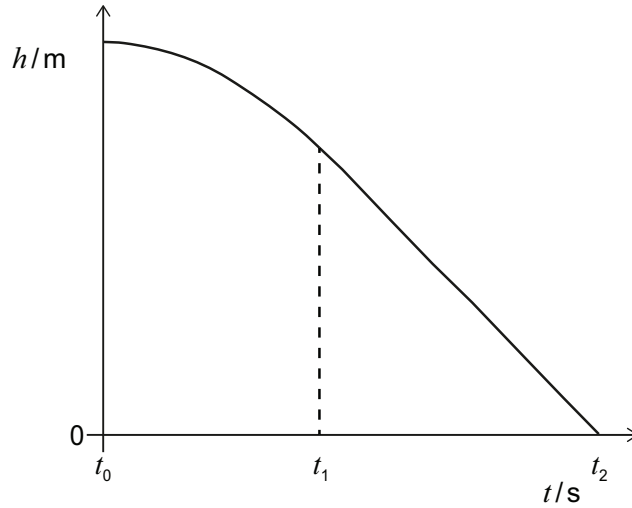

- a) In words, relate the speed of the ball to the gradient of the graph at time t_0 , and in the two time intervals t_0 to t_1 , t_1 to t_2 .

[6 marks]

Answer:

.....

.....

.....

.....

.....

.....

.....

.....

.....

.....

.....

.....

.....

.....

.....

.....

.....

.....

.....

b) The drag force on the ball caused by air resistance is given by F_d .

Using Newton's second law, find an equation for the acceleration a of the ball in terms of F_d , m , and g , where g is the gravitational field strength.

[2 marks]

Answer:

.....

.....

.....

.....

.....

c) The drag force on the ball is given by $F_d = \frac{1}{4}\pi\rho r^2 v^2$, where ρ is the density of the air, r is the radius of the ball, and v is the instantaneous speed of the ball.

Find an expression for the terminal speed of the ball v_t in terms of m , g , r and ρ .

[3 marks]

Answer:

.....

.....

.....

.....

.....

.....

.....

.....

d) Calculate the value of the terminal speed of the ball given that it has a mass $m = 25\text{ g}$, a radius $r = 25\text{ cm}$, and that the density of the air $\rho = 1.2\text{ kg m}^{-3}$.

(gravitational field strength = 9.8 N kg^{-1})

[2 marks]

Answer:

.....

.....

.....

.....

.....

e) Sketch a graph of the ball's speed against time, labelling the terminal speed of the ball.

In words, relate the acceleration of the ball to the gradient of your speed–time graph.

[4 marks]

Answer:

.....

.....

.....

.....

.....

.....

f) The speed of the ball varies with height according to the equation

$$\left(\frac{v}{v_t}\right)^2 = \left(1 - 10^{-\frac{cy}{m}}\right)$$

where $m = 25\text{g}$, $c = 0.051\text{ kg m}^{-1}$ and y is the distance the ball has fallen from the window; $y = 0$ at the start of the fall.

Calculate the distance that the ball has fallen when its speed is equal to 99% of its terminal speed.

[3 marks]

Answer:

.....

.....

.....

.....

.....

.....

.....

.....

.....

.....

.....

.....

.....

.....

.....

.....

.....

.....

.....

Question P2

Assume throughout this question that the cells and batteries have no internal resistance.

A light-emitting diode (LED) has the ideal I - V characteristic graph shown in Fig. 2a:

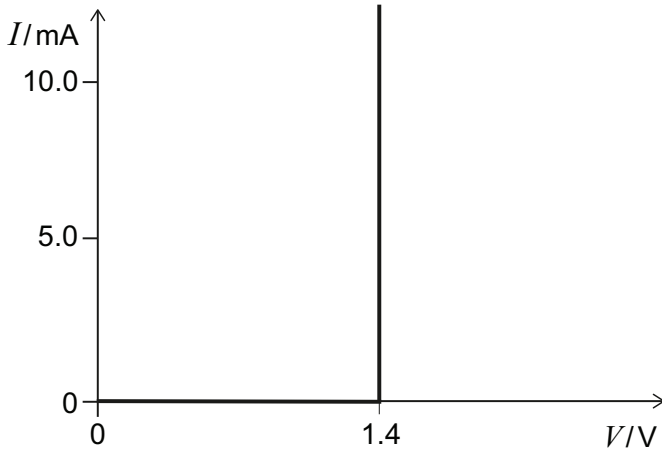

Figure 2a

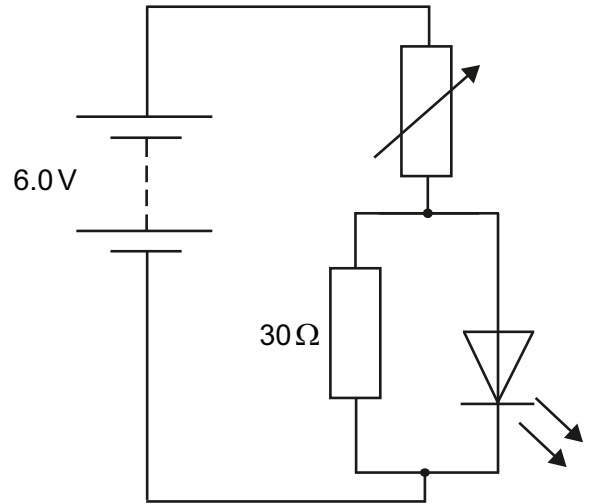

Figure 2b

If the potential difference across the LED is less than 1.4 V, no current passes through it. When a current does pass through the LED, the potential difference across it is always 1.4 V.

This LED is connected into the circuit shown in Fig. 2b, and the variable resistor is adjusted until there is a current of 8.0 mA through the LED. The battery has an emf of 6.0 V.

- a) (i)** What is the potential difference across the $30\ \Omega$ resistor? **[1 mark]**

Answer:

.....

.....

- (ii)** What is the current through the $30\ \Omega$ resistor? **[1 mark]**

Answer:

.....

.....

b) (i) What is the current through the variable resistor? **[1 mark]**

Answer:
.....
.....

(ii) What is the potential difference across the variable resistor? **[1 mark]**

Answer:
.....
.....

(iii) What is the resistance of the variable resistor? **[1 mark]**

Answer:
.....
.....

- c) The following circuit is constructed with a battery of emf 6.0 V, two fixed resistors, one variable resistor, and a voltmeter, as shown in Fig. 2c.

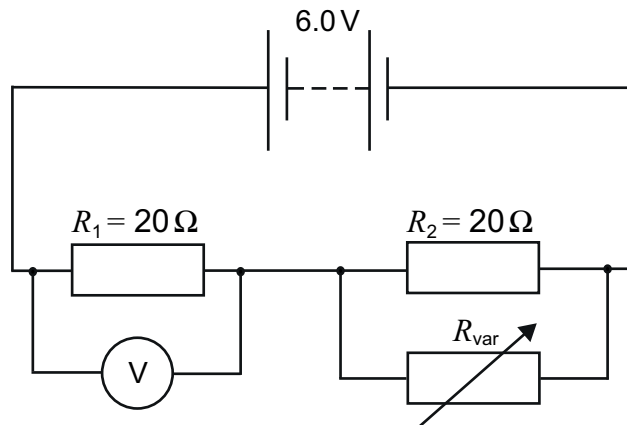

Figure 2c

$R_1 = R_2 = 20\ \Omega$, and R_{var} can be varied between 0 and $80\ \Omega$.

- (i) When R_{var} is set to $20\ \Omega$, what is the voltage shown on the voltmeter?

[1 mark]

Answer:

.....

.....

- (ii) Sketch a graph of the voltage shown on the voltmeter against R_{var} for values of R_{var} between 0 and $80\ \Omega$. Plot your result from part (i) on your graph.

[3 marks]

Answer:

- (iii) Calculate the potential difference across the variable resistor, and the power dissipated in the variable resistor, for $R_{\text{var}} = 0.0 \Omega, 5.0 \Omega, 20 \Omega, 50 \Omega$ and 80Ω .

[5 marks]

Answer:

R_{var} / Ω	
0.0	
5.0	
20	
50	
80	

- (iv) Using your results from part (iii), sketch a labelled graph of the power dissipated in the variable resistor against R_{var} from 0 to $80\ \Omega$.

[3 marks]

Answer:

- d) A potentiometer is a three-terminal device often used as a variable resistor by using only two of the three terminals (one end of the resistive track and the sliding contact). An example is shown schematically in Fig. 2d. In a logarithmic potentiometer the resistance varies with the angle of rotation, θ .

The graph in Fig. 2e shows how the logarithm of the resistance R_{AB} varies linearly with angle θ .

θ can vary between 0° and 270° .

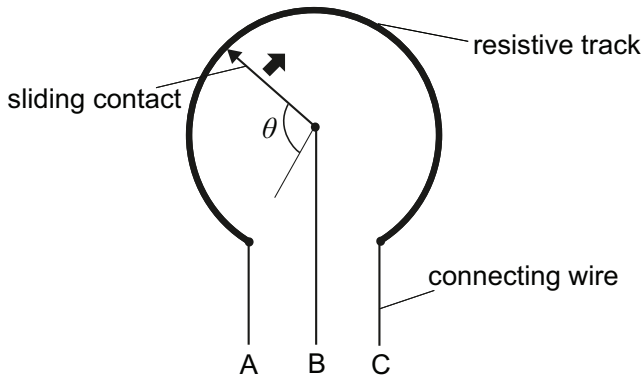

Figure 2d

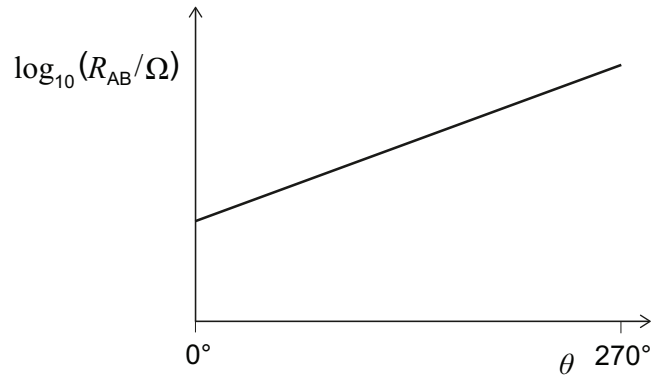

Figure 2e

If the resistance when $\theta = 0^\circ$ is $R_{AB} = 1.00 \text{ k}\Omega$, and when $\theta = 270^\circ$ is $R_{AB} = 2.00 \text{ M}\Omega$, what is the value of R_{AB} when $\theta = 110^\circ$?

[3 marks]

Answer:

.....

.....

.....

.....

.....

.....

.....

.....

.....

.....

This page is intentionally left blank for your rough working or notes.

H	He
1 1.008	2 4.003
Li	Be
3 6.941	4 9.012
Na	Mg
11 22.99	12 24.31
K	Ca
19 39.10	20 40.08
Rb	Sr
37 85.47	38 87.62
Cs	Ba
55 132.9	56 137.3
Fr	Ra
87	88
	Ac[†]
	89

Sc	Ti	V	Cr	Mn	Fe	Co	Ni	Cu	Zn	Ga	Ge	As	Se	Br	Kr
21 44.96	22 47.87	23 50.94	24 52.00	25 54.94	26 55.85	27 58.93	28 58.69	29 63.55	30 65.38	31 69.72	32 72.63	33 74.92	34 78.97	35 79.90	36 83.80
Y	Zr	Nb	Mo	Tc	Ru	Rh	Pd	Ag	Cd	In	Sn	Sb	Te	I	Xe
39 88.91	40 91.22	41 92.91	42 95.95	43 101.1	44 102.9	45 106.4	46 107.9	47 107.9	48 112.4	49 114.8	50 118.7	51 121.8	52 127.6	53 126.9	54 131.3
La*	Hf	Ta	W	Re	Os	Ir	Pt	Au	Hg	Tl	Pb	Bi	Po	At	Rn
57 138.9	72 178.5	73 180.9	74 183.8	75 186.2	76 190.2	77 192.2	78 195.1	79 197.0	80 200.6	81 204.4	82 207.2	83 209.0	84	85	86

symbol
atomic number
relative atomic mass (A_r)

*Lanthanides	Ce	Pr	Nd	Pm	Sm	Eu	Gd	Tb	Dy	Ho	Er	Tm	Yb	Lu
	58 140.1	59 140.9	60 144.2	61	62 150.4	63 152.0	64 157.3	65 158.9	66 162.5	67 164.9	68 167.3	69 168.9	70 173.0	71 175.0
†Actinides	Th	Pa	U	Np	Pu	Am	Cm	Bk	Cf	Es	Fm	Md	No	Lr
	90 232.0	91 231.0	92 238.0	93	94	95	96	97	98	99	100	101	102	103

Chemistry

Question C1

- a) Ketones react with hydroxylamine, NH_2OH , to give oximes. An example of such a reaction involving the ketone propanone is shown below:

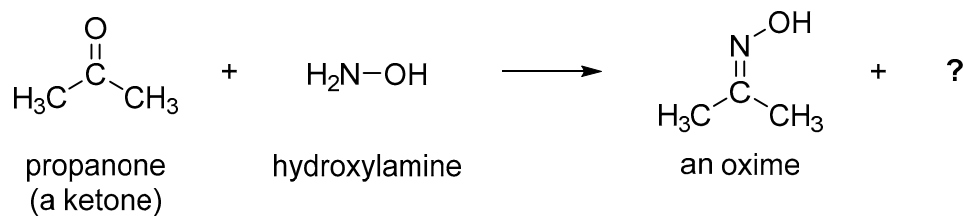

- (i) In addition to the oxime, this reaction produces a second product. Suggest what this molecule might be.

[1 mark]

Answer:

.....

- (ii) Draw the structure of the oxime that you would expect to be formed from the reaction of the ketone cyclohexanone with hydroxylamine.

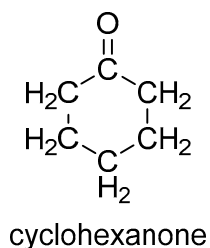

[2 marks]

Answer:

- (iii) Oximes are weakly acidic. For the oxime below, explain which hydrogen atom will be the most acidic and draw the structure of the resulting anion X^- .

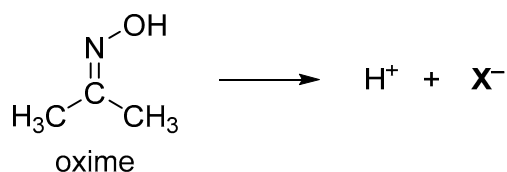

[3 marks]

Answer:

.....

.....

.....

- b) Under acidic conditions, oximes undergo the following rearrangement reaction (note carefully that there are two different groups R and R').

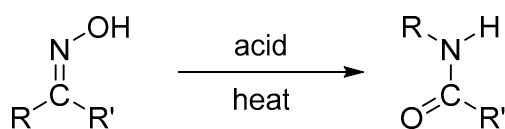

Give the analogous structures into which each of the following oximes rearrange under the same conditions.

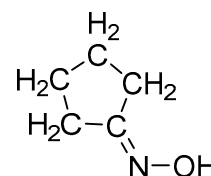
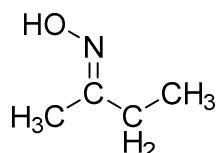
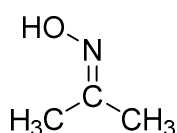

[4 marks]

Answer:

- c) Dimethylglyoxime reacts with Ni^{2+} ions in aqueous solution under mildly basic conditions to give a complex which is an insoluble red precipitate. The reaction involves two molecules of dimethylglyoxime and also results in the production of two H^+ ions.

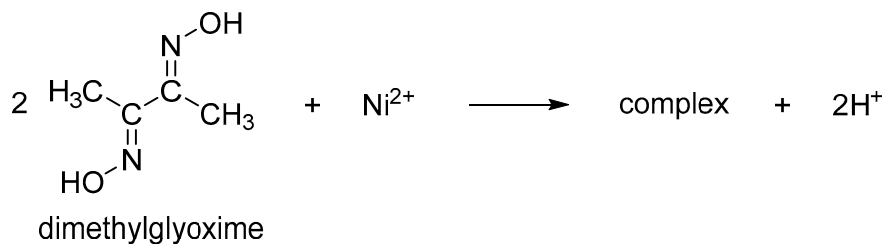

Assuming that the above equation is balanced, determine the **molecular formula** of the complex and its relative molecular mass; a structural formula is **not** required.

(Relative atomic mass data is given in the Periodic Table on page 14.)

[4 marks]

Answer:

.....

.....

.....

.....

.....

.....

.....

.....

.....

- d) The reaction between dimethylglyoxime and Ni^{2+} ions can be used to determine the nickel content of alloys by weighing the amount of the red precipitate produced from a known mass of a sample of an alloy.

A sample of mass 1.50 g of an alloy was dissolved in dilute acid and an excess of dimethylglyoxime was then added to the resulting solution. The pH was then adjusted to make the solution mildly alkaline, and this resulted in the formation of a red precipitate. The precipitate was carefully filtered off, dried and then weighed. The mass of the dry precipitate was 0.368 g.

Determine the nickel content of the alloy, expressed as a percentage by mass.

[4 marks]

Answer:

.....

.....

.....

.....

.....

.....

.....

.....

.....

.....

.....

.....

.....

.....

.....

- e) Other metal ions, such as Pd^{2+} or Pt^{2+} , also react with dimethylglyoxime to give insoluble precipitates. What effect would the presence of palladium in the alloy have on the value of the nickel content determined using the method in part d) ?

[2 marks]

Answer:

.....

.....

.....

.....

Question C2

- a) Write a balanced chemical equation for the reaction between $\text{CO}_2(\text{g})$ and $\text{OH}^-(\text{aq})$, giving $\text{CO}_3^{2-}(\text{aq})$ as one of the products.

[1 mark]

Answer:

.....

.....

- b) An organic molecule is known to contain C, H and O only. A sample of mass 0.100 g is carefully burnt in the presence of excess oxygen. The resulting gases are passed over a desiccant (drying agent), and it is observed that the mass of the desiccant increases by 0.0931 g.

After passing through the desiccant the gases are bubbled through 25.0 cm^3 of a solution of 1.00 mol dm^{-3} NaOH. The solution is then titrated against 1.00 mol dm^{-3} HCl, and the end point is found to be when 14.7 cm^3 of the acid has been added.

- (i) Calculate the amount in moles of H_2O produced by the combustion.

[2 marks]

Answer:

.....

.....

.....

- (ii) Calculate the amount in moles of CO_2 absorbed by the NaOH solution.

[4 marks]

Answer:

.....

.....

.....

.....

.....

.....

.....

(iii) Hence determine the empirical formula of the organic molecule.

[6 marks]

Answer:

.....

.....

.....

.....

.....

.....

.....

.....

.....

.....

.....

.....

.....

.....

.....

.....

.....

.....

.....

.....

.....

c) Determine the oxidation state of the metal atom or atoms in the following species.



[1 mark]

Answer:

.....

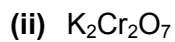

[2 marks]

Answer:

.....

.....

.....

d) Write a balanced chemical equation in which Fe^{2+} is oxidised to Fe^{3+} by MnO_4^- in an **acidic aqueous solution** and in which the Mn is reduced to a species with oxidation state +2. Your equation must balance for both atoms and charge, and you may **not** use free electrons (e^-) to achieve this.

[4 marks]

Answer:

.....

.....

.....

.....

.....

.....

.....

.....

.....

.....

This page is intentionally left blank for your rough working or notes.

Biology

Question B1

- a) Sketch a simple diagram of a eukaryotic cell, and label the locations where DNA transcription and RNA translation take place.

[2 marks]

Answer:



- b) When RNA is translated into protein, it is read in triplets (codons).

What proportion of codons might be viewed as redundant in the genetic code (i.e. in excess of the minimum needed to code for all amino acids)?

[2 marks]

Answer:

.....

.....

.....

.....

.....

c) What is an advantage of having more codons in the genetic code than there are amino acids? **[2 marks]**

Answer:

.....

.....

.....

.....

.....

d) A ribosome can translate 18 bases per second.

How many seconds would it take to produce a protein that was 299 amino acids long? **[2 marks]**

Answer:

.....

.....

.....

.....

.....

e) Imagine that an alien organism is found that translates its RNA using pairs of nucleotides instead of triplets.

During translation, the alien organism can use 50 possible amino acids (rather than the 20 found in humans).

What is the minimum number of different types of nucleotides that would be needed to code for all of the possible amino acids? **[2 marks]**

Answer:

.....

.....

.....

.....

.....

f) Using examples, describe the changes that can occur in DNA sequences and explain how these changes can lead to diseases.

[10 marks]

Answer:

.....

.....

.....

.....

.....

.....

.....

.....

.....

.....

.....

.....

.....

.....

.....

.....

.....

.....

.....

.....

.....

.....

.....

.....

.....

Question B2

The diagram below shows eight $2\text{ m} \times 2\text{ m}$ quadrats that have been placed into a $14\text{ m} \times 10\text{ m}$ field that has recently been colonised by a small invasive plant (each plant is shown by a flower symbol).

[diagram not to scale]

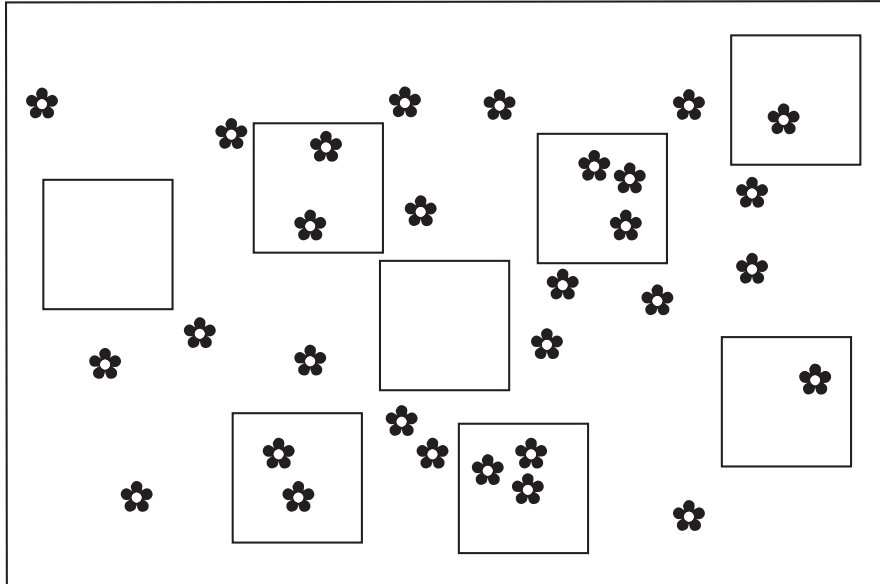

a) Describe one benefit **and** one problem associated with using quadrats in a study like this.

[2 marks]

Answer:

.....

.....

.....

.....

.....

b) Calculate the frequency of occurrence of the species in the quadrats.

[1 mark]

Answer:

.....

.....

c) Calculate the mean number of plants found per square metre in the quadrats.

[2 marks]

Answer:

.....

.....

.....

.....

.....

d) For the field as a whole, this population grows by 70 individuals per week.

How long will the population take to reach an average density of two plants per square metre in the 14 m × 10 m field?

[2 marks]

Answer:

.....

.....

.....

.....

.....

e) The invasive plant only produces flowers once every 5 years.

Explain why the plant produces flowers, and why flowers might be produced on this timescale.

[3 marks]

Answer:

.....

.....

.....

.....

.....

.....

.....

.....

.....

This page is intentionally left blank for your rough working or notes.